

AINSWORTH

XP-Series

Toploading Balances

XP-300A/XP-600A/XP-1500A/XP-3000A

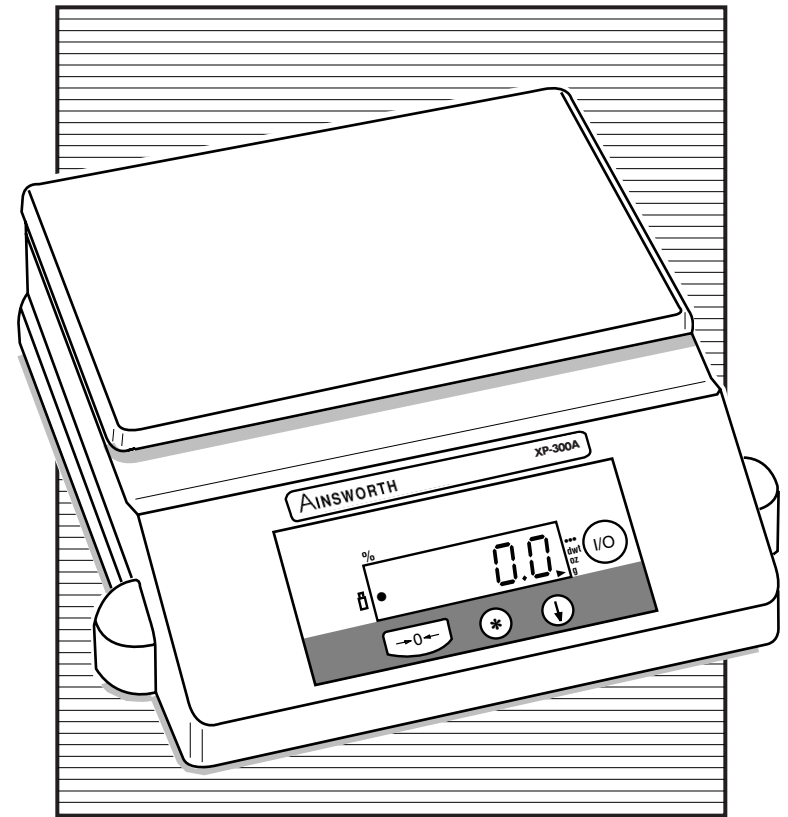
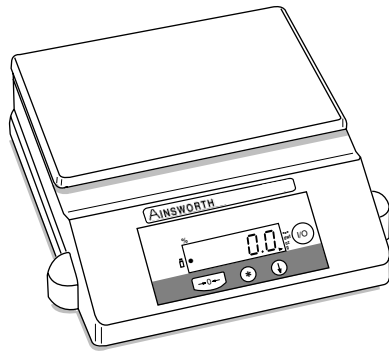

AINSWORTH

Precision weighing and measuring instruments since 1880

6542 Fig Street • Arvada, Colorado 80004
303-431-7255 • 1-800-321-1135 • Fax 303-423-4831

Operation Manual

902393.1

Rev. A

You have purchased a quality precision weighing instrument that requires handling with care.

Read entire contents of this **Operation Manual** prior to operating your new AINSWORTH balance.

Disclaimer Notice

Calibrate your balance using a reference weight of the appropriate tolerance (class). An instrument can be no more accurate than the standard to which it has been compared. For assistance in the selection of reference weights, please contact the factory.



Caution!

Changes or modifications not expressly approved by the manufacturer could void the user's authority to operate this equipment.



Warning

Never lift balance by the weighing pan as this may cause damage to internal mechanisms.

Always lift and transport the balance by its base, including removal from packing materials!

Warning

Do not drop weights on pan.

Damage will occur to the balance's internal mechanisms.

Note:

Damage may occur if load exceeds 150% of maximum capacity.

Note:

This product may contain a lead acid battery. The user is responsible for disposing of the unit in accordance with local ordinances and regulations.

AINSWORTH

Precision weighing and measuring instruments since 1880

6542 Fig Street • Arvada, Colorado 80004
303-431-7255 • 1-800-321-1135 • Fax 303-423-4831

Cleaning Instructions

The exterior surfaces of the product may be cleaned with a mild water-based detergent and a lint-free nonabrasive cloth. Alternatively, isopropyl alcohol may be used. Do not immerse the product in any liquid.



Warning

Never lift balance by the weighing pan as this may cause damage to internal mechanisms.

Always lift and transport the balance by its base.



Warranty Instructions

1. Please return the prepaid, pre-addressed Purchase Registration Card promptly upon your purchase of the Ainsworth product. The return of the card is not a condition precedent to warranty coverage.
2. If you have any questions about a Ainsworth product, please call toll-free, **1-800-321-1135** or FAX a description of the problem to (303) 423-4831 for technical assistance.
3. If it becomes necessary to return your Ainsworth product for service, you must obtain a **"Return Authorization Number"**. Please pack the product securely in its original approved packing carton or an other suitable container. Include your Return Authorization Number on the shipping label. Shipping charges must be fully prepaid.

Return to authorized distributor or :

Ainsworth Company
6542 Fig Street
Arvada, Colorado 80004

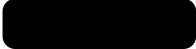
Maintenance and Troubleshooting

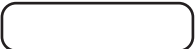
Display Shows:	Cause:	Remedy:
 (Blank Screen)	I/O key pressed	Press the I/O key. to turn OFF Displays.
	Power cord not	Connect cord. connected.
	No power to outlet or improper voltage.	Check power supply. Check power supply and voltage switch.
	Temporary fault	Disconnect and reconnect power cord. (Wait at least five seconds before reconnecting.)
	Weight exceeds balance capacity.	Reduce weight.
	Pan obstructed.	Check pan placement.
	Balance operating error.	Re-calibrate balance.
	Load cell damaged.	The most common cause is from objects being dropped onto the weighing pan or from the balance itself being dropped. The balance must be returned for service.
 (No stability indicator)	Air movement around balance.	Move balance to stable, draft-free location.
E-02	Usually detected when the calibration operation is being attempted. It is usually the result of the balance being exposed to vibrations, air drafts or unstable environments.	The balance must be placed in a stable environment before calibration occurs.
	Pan was not in place when unit was turned on.	Turn unit off and place pan on and turn unit on.
E-30	This is an indication that an electronic malfunction has occurred.	The unit must be returned to the factory for evaluation.
E-54	This fault will appear on the display when the unit is powered on. This occurs when the electronics are no longer within the factory set parameters.	The most common cause is from objects being dropped onto the weighing pan or from the balance itself being dropped. The balance must be returned for service.

Introduction

Thank you for choosing one of our precision instruments. Your balance is designed and manufactured to the most rigorous standards in order to give you years of service. First, check the contents of the shipping carton. You should find the following:

- Manual
- Balance
- AC Adapter
- Cover Pan

Next, follow the instructions for installing your balance.

Now you're ready to begin using your balance. To take advantage of its many features, carefully read your operating manual. It contains step-by-step procedures, examples, and other vital information.

Finally, remember to return your completed warranty card within ten days and to record all purchase information in the space provided on the back cover of your manual.



Warning: Use of this product in a manner not specified by the manufacturer may impair any safety protection provided by the equipment!

Specifications

Model	XP-300A	XP-600A	XP-1500A	XP-3000A
Range	300g	600g	1500g	3000g
Readability	0.01g	0.02g	0.05g	0.1g
Linearity	±0.01g	±0.02g	±0.05g	±0.1g
Pan Dimensions	5" x 7" (127 x 178mm)	5" x 7" (127 x 178mm)	5" x 7" (127 x 178mm)	5" x 7" (127 x 178mm)
Permissible Calibration Weights	200g	500g	1000g	2000g
Temperature	15 - 40 °C			
Humidity	80% for temperature to 31°C, decreasing linearly to 50% relative humidity at 40°C			
Altitude	3000m			

Common Specifications: Unit dimensions (L x W x H) 8.2 x 8.3 x 2.7" (208 x 211 x 69mm); Net Weight: 3.75 lbs. (1.7 kg). Power: 15 VDC, 100mA, AC adapter included. Mains supply voltage fluctuations not to exceed ±10% of nominal supply voltage. Equipment id suitable for continuous operation with AC adapter/charger. Pollution degree:2; Installation category: II; Sound Pressure Level emitted by equipment does not exceed ambient noise. Storage/Transport Temperature: -20° - +40°C.

NOTE: The battery is not a user serviceable part. If the battery does not recharge with use of AC adapter, contact an authorized service technician.



Caution: Use AC adapter/charger supplied with unit only!
Consult your Ainsworth dealer for replacement.

Preparation

- This product is intended for indoor use and portable applications.
- Select a suitable work area.
- Work area should be relatively free from drafts and vibrations.
- Work surface should be level and rigid.
- Do not locate near magnetic materials or equipment/instruments which use magnets in their design.
- Avoid areas which have variations in room temperatures or have excessive room temperatures. Room temperatures above 105°F/40°C or below 60°F/15°C could affect balance operation and accuracy.

Installation

- Remove balance and accessories from the carton. Save packing material for transportation purposes.
- A rechargeable battery is already installed in your balance.
- Charge balance for 12 hours before using on battery power.
- When the battery icon flashes, you must recharge the unit.
- If using the AC adapter, insert power cord into the receptacle located on the rear of the unit. Firmly push in the plug.
- Allow the balance to warm up for 30 minutes prior to use.

Your balance features a numeric display that continuously shows your weighing results. The number of decimal places displayed depends on the XP model.

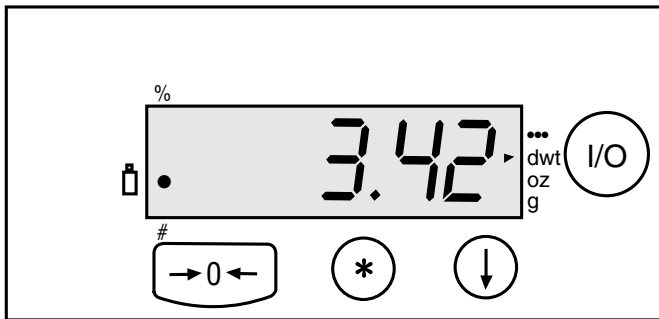

Function Keys

- I/O** Turns balance ON or OFF, or Standby if AC adapter is connected.
- ↓** Scroll; for selecting various units of weight or options.
- *** Print/Menu
- 0-** Zero/Tare; returns display to zero, exits from menu.

Hardware Handshake

With a 4-wire interface, 1 or 2 more characters can be transmitted after CTS.



Note:

These connections must be made when interfacing the balance through the RS232C port!

Data Interface Cable Pin Configuration For XP-Series Balances

XP Series Balance 9-Pin port		Standard RS-232 9-Pin Connector
RxD 2	←→	3 TxD
TxD 3	←→	2 RxD
DTR 4	←→	4 DTR
Signal Ground 5	←→	5 Signal Ground
CTS 8	←→	8 CTS

XP Series Balance 9-Pin Port		Standard RS-232 25-PIN Connector
RxD 2	←→	2 TxD
TxD 3	←→	3 RxD
DTR 4	←→	20 DTR
Signal Ground 5	←→	7 Signal Ground
CTS 8	←→	5 CTS

RS232C Interface (Option)

The RS232C interface is an option added at the factory at the time of ordering your XP balance.

Data Input Format

You can connect a computer or printer to your balance to send commands via the balance interface port to control balance functions and application.

A control command can have up to 4 characters. Each character must be transmitted according to the communication port setting for data transmission.

Communications Port Settings

Baud	Data Bits	Parity	Stop Bit
9600	7bit	Space	1

Flow Control = None or Xon/Xoff
 Line Delay 50ms
 Character Delay 50 ms

Format for Control Commands

Format:	Esc	!	CR	LF
Esc:	Escape		CR: Carriage Return (optional)	
!:	Command character		LF: Line Feed (optional)	

Command character:	!	Meaning
	K	Very Stable Conditions
	L	Stable Conditions
	M	Unstable Conditions
	N	Very Unstable Conditions
	O	Disable Keypad
	P	Print Display
	R	Enable Keypad
	S	Reset Balance
	T	Tare and Zero (combined)
	U	Tare (tare only)
	V	Zero
	W	External Calibration/Adjustment

Operation

Your new balance weighs in different units and can perform parts counting and percent of weight functions.

A. Taring (Zeroing)

All models have taring capabilities up to their total weight capacity (varies with each model).

1. Place sample container on pan.
2. Press the **-0-** key to zero the balance.
3. Add your sample, when the balance is stable the display is showing the weight of the sample.

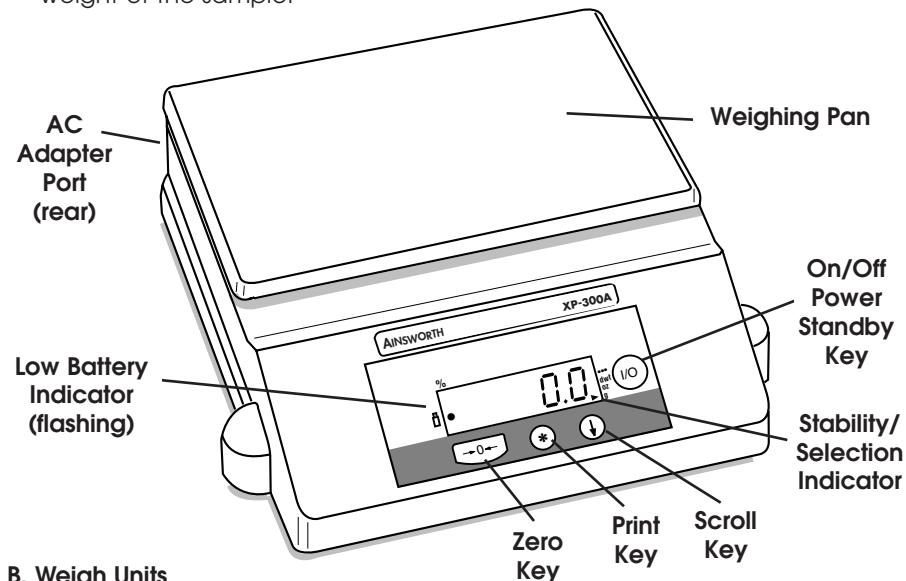

B. Weigh Units

1. To toggle between pennyweight, ounces, grams, counting features (count or percentage depending on which one is activated) and optional unit (***) , press the **↓** key.
2. To change the optional unit, press and hold down the ***** key for 3 seconds. The display will read "Unit".
3. Press the **↓** key to cycle through the different weight modes.
4. Press the **-0-** key when the desired mode appears.

Lb	Pounds	GRAIN	Grains
TrOZ	Troy Ounces	CARAT	Carats
LAEL	Tael, Hong Kong		

C. Calibration

1. To calibrate the balance, tare or zero the balance with no weight on pan, press and hold down the * key for 3 seconds. The display will read "Unit". Press the * once, the display will now show "CAL".
2. Press the ↓ key. The calibration weight of the balance in grams will be displayed.
3. Place the correct weight on the balance. After a few seconds the display will flash indicating the value has been accepted.

D. Count or Percentage Mode Setup

1. Press and hold * key for 3 seconds. The display will read "Unit". Press the * key repeatedly until unit displays "Count".
2. Press the ↓ key to correct number of pieces to be counted is displayed: 10, 20, 50, 100 or P100 for percentage mode.
3. Press the -0- key to enter correct count or percentage mode.

E. Set reference weight for Count or Percentage Mode

1. Tare unit by pressing -0-.
2. Place reference weight on balance.
3. Press the ↓ key repeatedly until the stability icon goes to % of #.
4. Balance should display reference mode setup 10, 20, 50, 100.



Note: If balance power is removed or turned off, the reference weight must be redone.

F. Auto-Shut Off

If a fully charged balance loses AC power, it will be able to use its battery backup for 48 hours of weighing. When operating on battery backup the display will flash after 4 minutes if there is no weight change. If left in this mode, the display will continue to flash for 2 additional minutes, after which the balance will shut itself off.

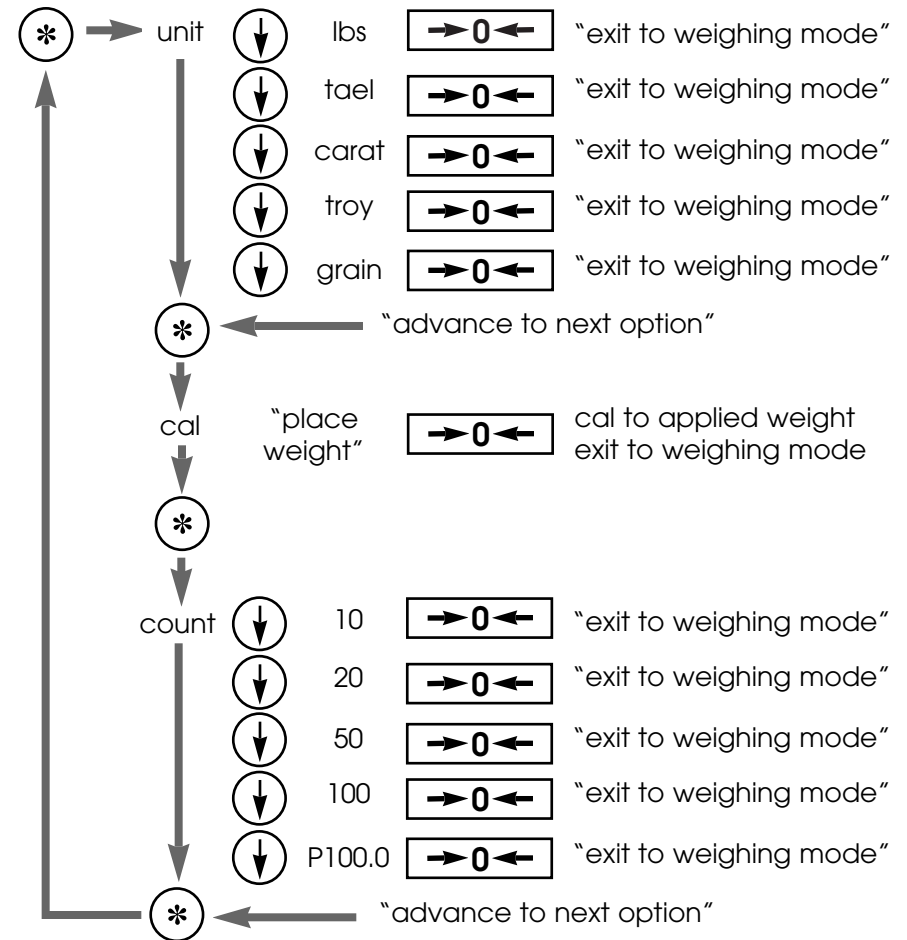
Menu Tree

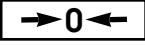

	Function in Weighing Mode	Function in Menu Mode
	Zero's the balance	Exits from current point weighing mode, saves last options
	Pushed momentarily sends printer string out optional serial port. Pushed for 3 seconds enters menu mode.	Advances mode select to next menu option.
	Advances display options to next clockwise option	Cycles through selections at current menu level

- Notes:**
1. Text in quotes above indicates an action to occur (i.e., "place weight")
 2. Text not in quotes is the display message at that level (i.e., count or tael)
 3. P100.0 is used to denote percentage weighing

Menu Level Functions:

unit	selects the units to be displayed when in free units mode
cal	calibrates the unit to the applied weight
count	selects the reference quantity that the applied load will represent and the mode to operate in